

Balanced Vertical Slider TBVS – With Tilt Facility

Panel Sliding Orientation

TBVS version

- Panels slide both up and down
- Panels can't be removed
- Panels have easy clean tilt facility (non supported)



Closed



Part Open



Part Open



Tilting

Technical Information

Panel Configuration

Both panels will Slide.

Panels Cannot Be Removed.

Bottom panel will slide up in front of top panel, Top Panel will slide down behind the lower panel. Panels are self-supporting and will stay in opened position as required.

Panels will not slide to the full centre position.

Panels Can be tilted out of the frame for easy clean access to the inner surface of the secondary glazing. Panels are not self-supporting in this mode and attention the operation and maintenance manual is advised.

Panels removable

No

Size

Min 300w x 700h, 4mm glass max 1500 x 3000, 6/6.8mm glass max 1400mm x 2700mm

Glass

Standard glass 4mm tough - Max glass thickness 6.8 laminate

Thermal Performance: Variable

Standard 2.5 w/m²K / *Low-E 1.8 w/m²K

Acoustic Performance: Variable

Mid-Range Spec* 47dB / High spec 53dB
*Certificated

Specification

- All frames include PVC-U trim as standard – Painted PEFC timber available upon request.
- Aluminium 6063 T6 alloy to BS EN 755 standard, power coated to BS 6496 to 60 micron finish.
- Stock finishes: White – Interpon SA 098E high gloss, anodised.
- The sub-frame is manufactured from primed high quality, environmentally certified (MTCS) engineered timber.
- Standard sizes 45mm x 21mm & 62mm x 21mm.
- All Frames are factory glazed.
- Standard gasket colour is white.

In line with our company policy of continuous product development and improvement Clearview reserves the right to make minor alterations without notice.

Optional Extras

- Black Gasket
- Locking Fitch Catch
- Chubb Lock
- Travel Limit Stop
- 25mm x 25mm box to support where stacked white aluminium coupling / stacking interlock
- Trickle vents / acoustic trickle vents
- RAL colour
- Fly screen
- Timber sizes other than standard

Standard Frame Diagram

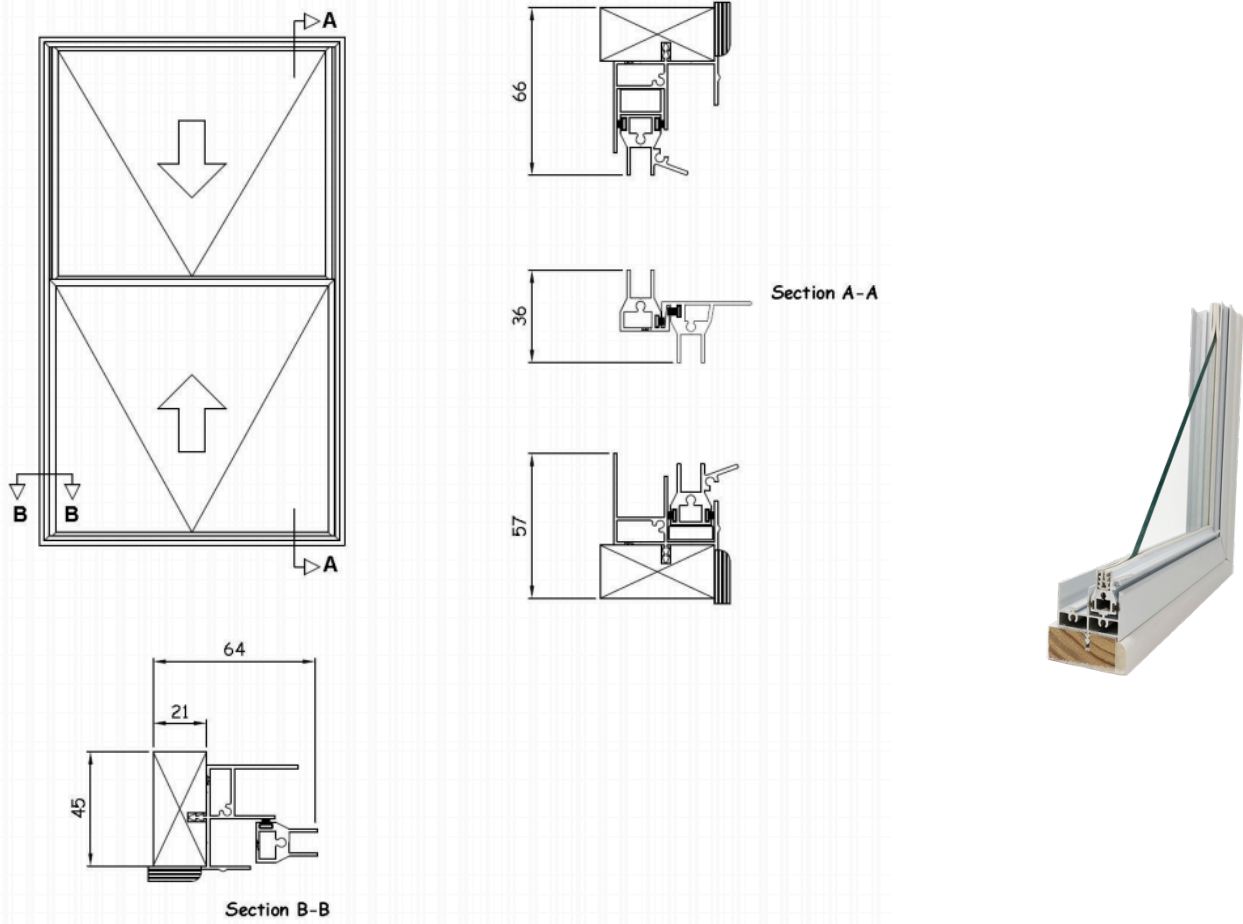

All units can be supplied in a Face or Reveal Fix drilled orientation.

Other Frame options available on Request.

Fixing Options

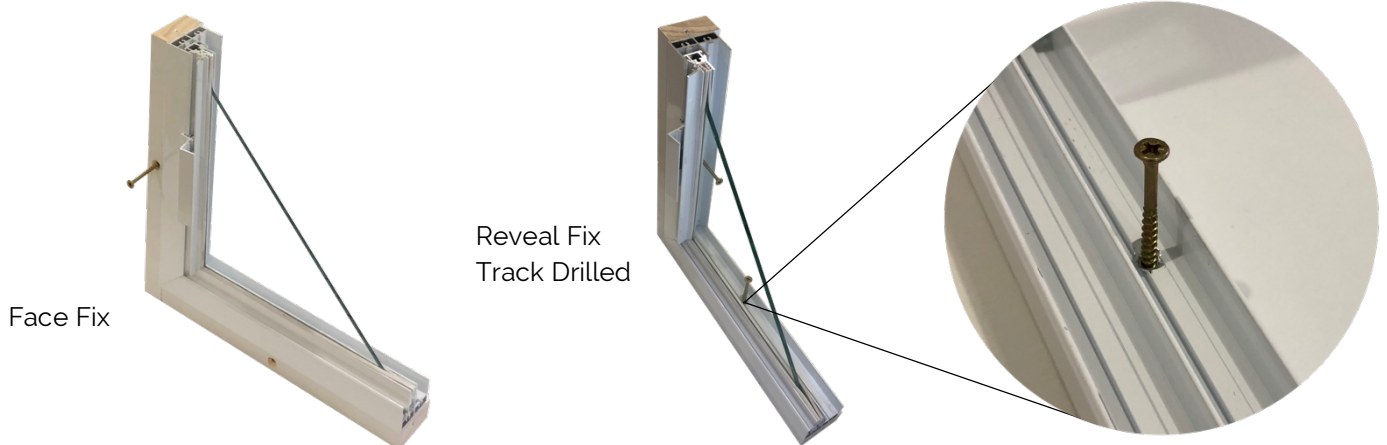

Images are for representation purposes only and may differ from some product options.

XL Frame Diagram

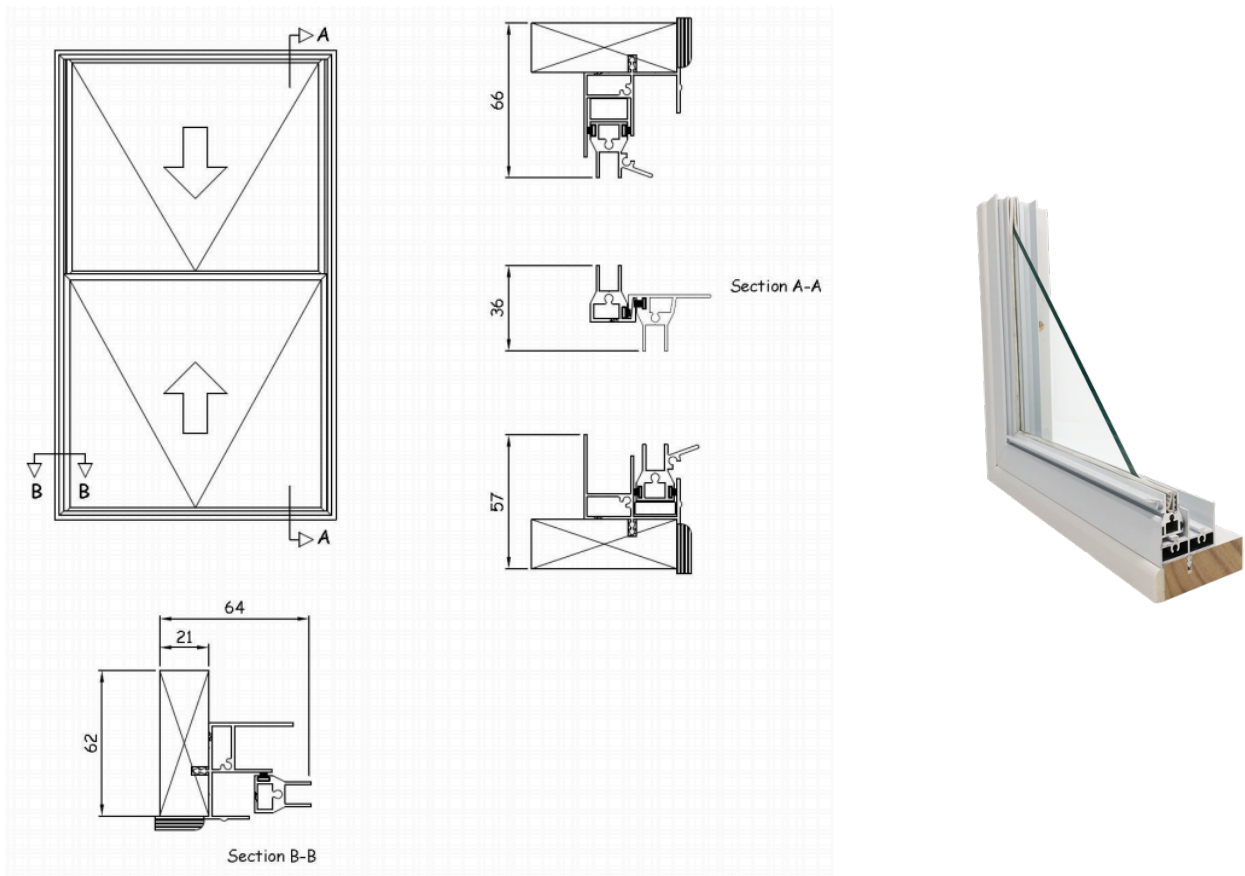

Classic XL Frame Depth Options

50 x 21 62 x 21 70 x 21 80 x 21 (other frames available on request)

The XL Frames give more stable installation when in a standalone reveal fix orientation. Smoother running of horizontal sliding panels. No visible screw heads in the aluminium tracks it will also increase the air-gap in a face fix orientation.

All units can be supplied in a Face or Reveal Fix drilled orientation.

Fixing Options



Images are for representation purposes only and may differ from some product options.

Timber Modification Options

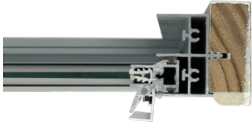

Standard Timber Option



XL Timber Option



Bevelled Timber for Splayed Reveal



Example of Splayed Reveal



Angled Bay Bevelled Timber

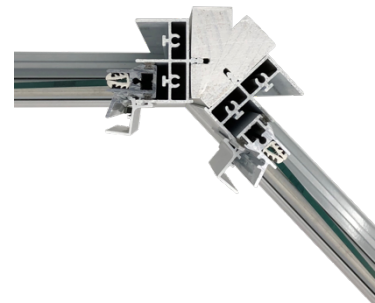

Angled Bay Connected Timbers



Square Bay Bevelled Timber

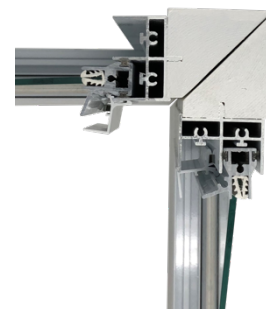

Square Bay Connected Timbers

Images for illustration purposes only

Frame Shape Options

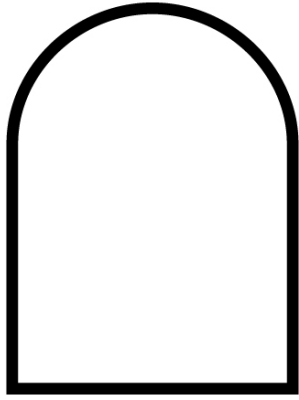

Standard Arch

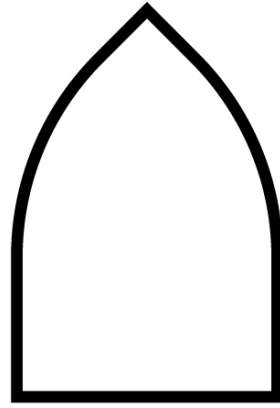

Gothic Arch



Please get in touch with one of our friendly team today for help & advice.



Online Help Centre
[Visit our Online Help Centre >>](#)



Fast Quote
[Get a fast quote online >>](#)



Email
info@clearviewsg.co.uk



Phone
0114 294 5018

