

Hinge Unit – With Tilt Facility HHUT

Panel Orientation

HHUT version HL/ HR/ TH

- Hinge position can be specified to the left, right or top.
- Panels can open by 180 degrees
- Panel can be tilted for unobtrusive ventilation.
- Panels can't be removed



Closed



Open



Tilting

Technical Information

Panel Configuration

Hinging Panel, opening inwards from fixed frame. Hinges can be positioned on either the left or right side or the Top.

Butt Hinges fitted as standard opening to 1800 (Friction Stay Hinges optional Extra).. Handle height is placed centrally on the opposing side to the hinges. Handle position can be specified at the point of order.

The Tilt & Turn Facility is an Optional: Side hung units can be fitted with an optional extra Tilting facility for unobtrusive ventilation.

Panels Cannot be removed.

Panels removable

No

Size

Min 600w x 500h, 4mm glass max 1400 x 2400, 28mm Sealed Unit DG glass max 1400mm x 2400mm

Glass

Standard glass 4mm tough - Max glass thickness 28mm Sealed Unit DG.

Thermal Performance: Variable

Standard 2.5 w_m2K / *Low-E 0.9 w_m2K

Acoustic Performance: Variable

Mid-Range Spec* 51dB / High spec 54dB
*Certificated

Specification

- All frames include PVC-U trim as standard – Painted MDF or PEFC timber available upon request.
- Aluminium 6063 T6 alloy to BS EN 755 standard, power coated to BS 6496 to 60 micron finish.
- Stock finishes: White – Interpon SA 098E high gloss, anodised.
- The sub-frame is manufactured from primed high quality, environmentally certified (MTCS) engineered timber.
- Standard sizes 45mm x 21mm & 62mm x 21mm.
- All Frames are factory glazed.
- Standard gasket colour is white.

In line with our company policy of continues product development and improvement Clearview reserves the right to make minor alterations without notice.

Optional Extras

- Black Gasket
- Locking Fitch Catch
- Chubb Lock
- Travel Limit Stop
- 25mm x 25mm box to support where stacked white aluminium coupling / stacking interlock
- Trickle vents / acoustic trickle vents
- RAL colour
- Fly screen
- Timber sizes other than standard

Standard Frame Diagram

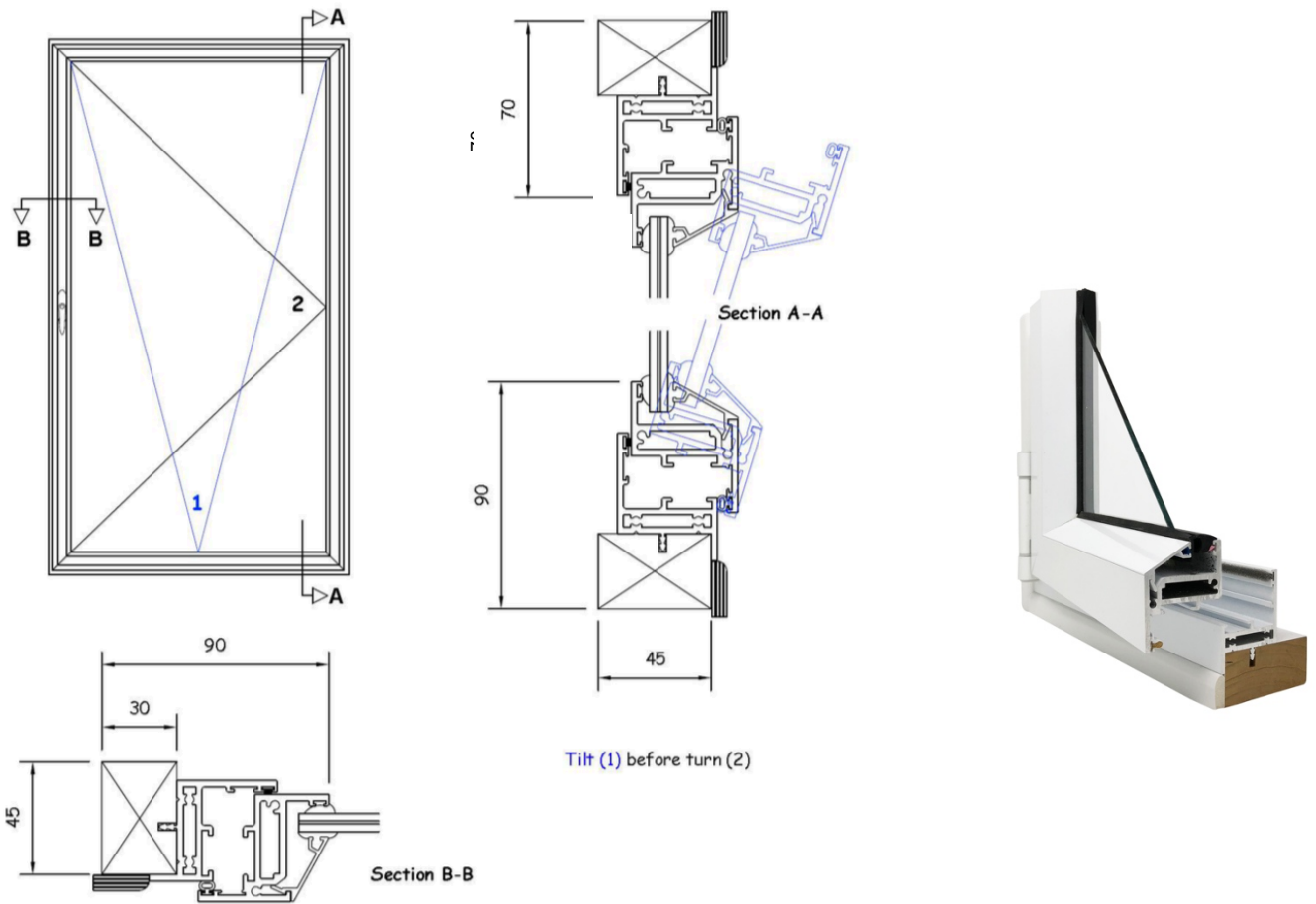

All units can be supplied in a Face or Reveal Fix drilled orientation.

Other Frame options available on Request.

Fixing Options



Images are for representation purposes only and may differ from some product options.

XL Frame Diagram

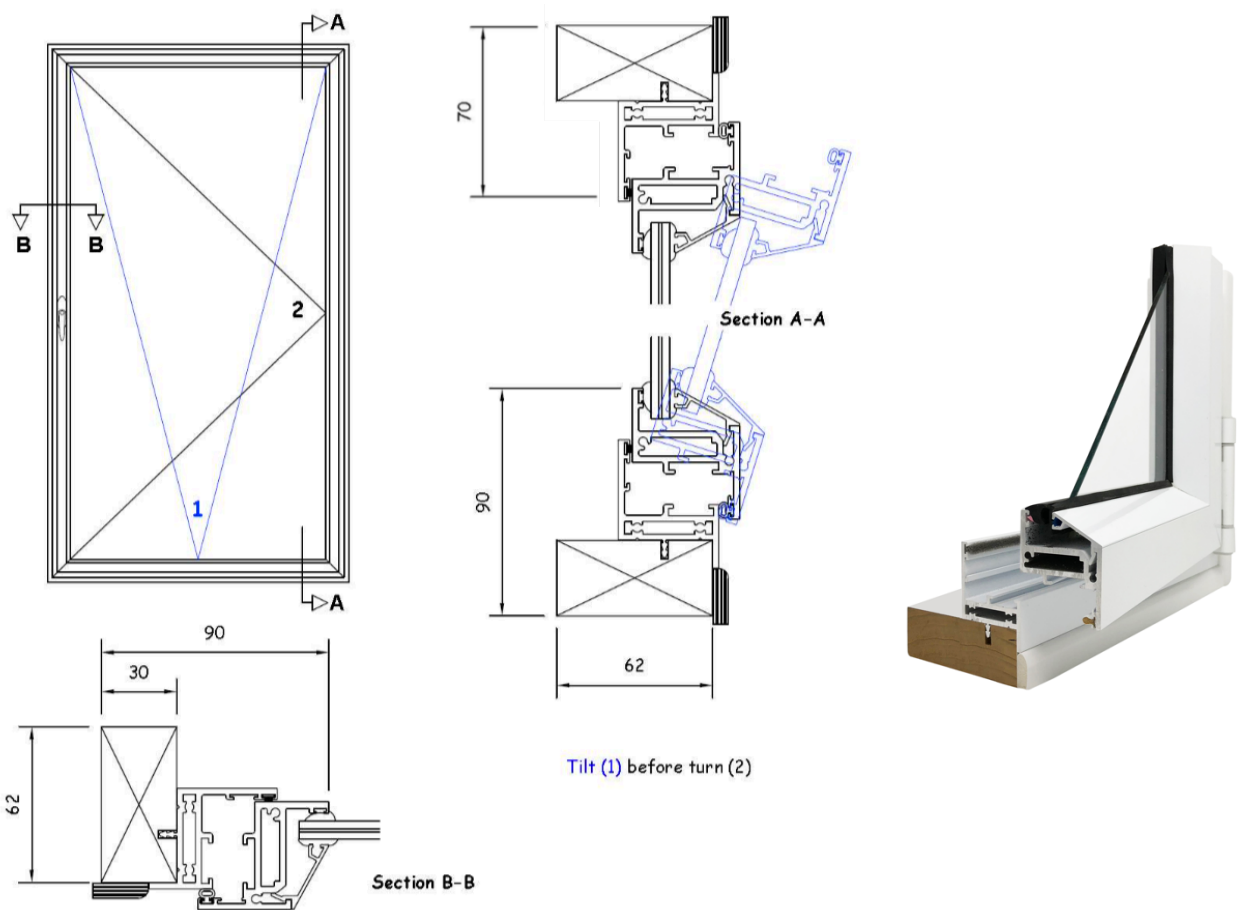

Forte XL Frame Depth Options

62 x 30 70 x 30 80 x 30 (other frames available on request)

The XL Frames give more stable installation when in a standalone reveal fix orientation. Smoother running of horizontal sliding panels. No visible screw heads in the aluminium tracks it will also increase the air-gap in a face fix orientation.

All units can be supplied in a Face or Reveal Fix drilled orientation.

Fixing Options



Images are for representation purposes only and may differ from some product options.

Timber Modification Options

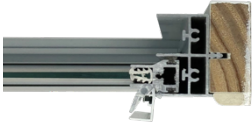

Standard Timber Option



XL Timber Option



Bevelled Timber for Splayed Reveal



Example of Splayed Reveal



Angled Bay Bevelled Timber

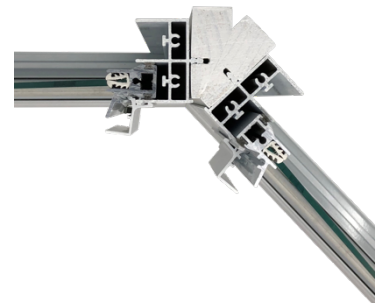

Angled Bay Connected Timbers



Square Bay Bevelled Timber

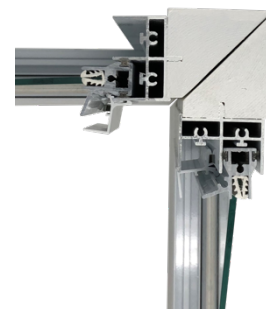

Square Bay Connected Timbers

Frame Shape Options

Subject to specific design requirement.

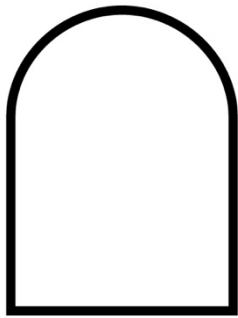

Standard Arch

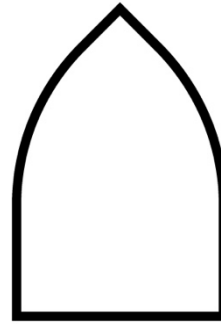

Gothic Arch

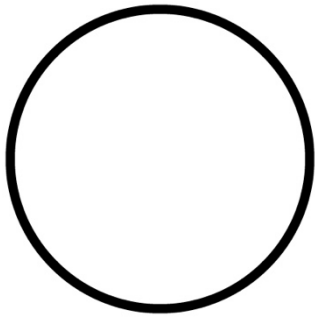

Round

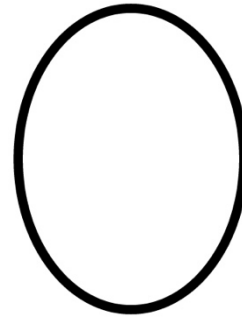

Oval

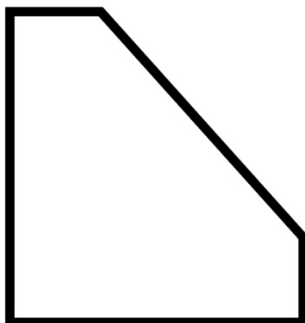

Chamfered

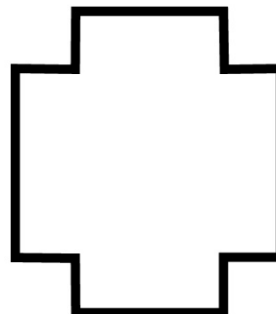

Notched

Notched window showing 4 notches – notches are charged per notch

Templates are required from the customer



Please get in touch with one of our friendly team today for help & advice.



Online Help Centre
[Visit our Online Help Centre >>](#)



Fast Quote
[Get a fast quote online >>](#)



Email
info@clearviewsg.co.uk



Phone
0114 294 5018

